



**We start your  
innovations**

# Machines

FOR THE PRODUCTION OF SHADING TECHNOLOGY



# Table of Contents

- 01 ABOUT THE COMPANY
- 02 MACHINES - INTERIOR
- 03 MACHINES - EXTERIOR
- 04 ACCESSORIES
- 05 SERVICES AND TECHNOLOGIES
- 06 COMPONENTS
- 07 CONTACT

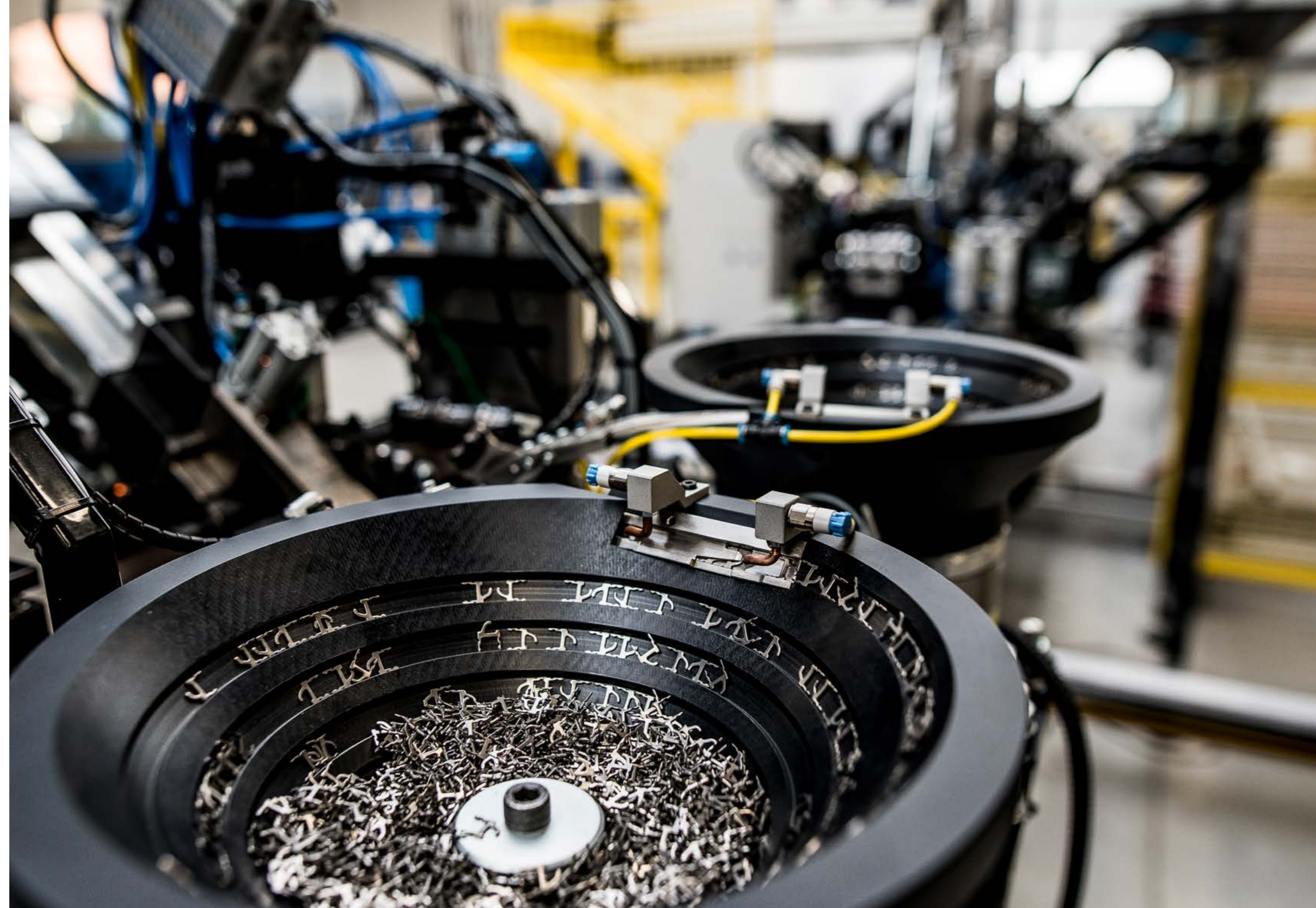

# Values

## INNOVATION

We are innovative in our thinking, control and application of the latest technologies.

## QUALITY

Our products are of world-class quality.

## STABILITY

We meet the needs of our customers, we look for new solutions and together we customize the products.

## SERVISING

We guarantee fast service and delivery of spare parts to our customers.

ABOUT THE COMPANY ZEBR

# Customer first

We are a self-confident, family-owned and socially responsible company. We supply our customers with equipment and components for the production of shading technology.

We offer products of world-class quality. We are a reliable partner for our customers on the way to innovative solutions that move them forward.



## OUR History

1991

Establishment of the company by the current owner, František Zelinka

1993

First semi-automatic machine for processing slats

1999

The VT12NC machine launched on the market

2004

Completed construction of a new production complex

2006

Introduction of the TRIANGL14NC line for 3 types of profiles at the fair in Stuttgart.

2009

Opening of the research and development center

2016

Completion of the development of the 3rd generation riveting

2018

Implementation of the new production control system

2017

Construction of a new assembly hall and expansion of the R&D centre

2019

Launch of the pressure casting technology

2020

Successful completion of cooperation on the development of the Raman spectrometer

2021

Launch of the ZEBR Cloud service enabling online monitoring of production statistics

2023

Launch of the NPD process for new product development

František Zelinka  
founder of the company

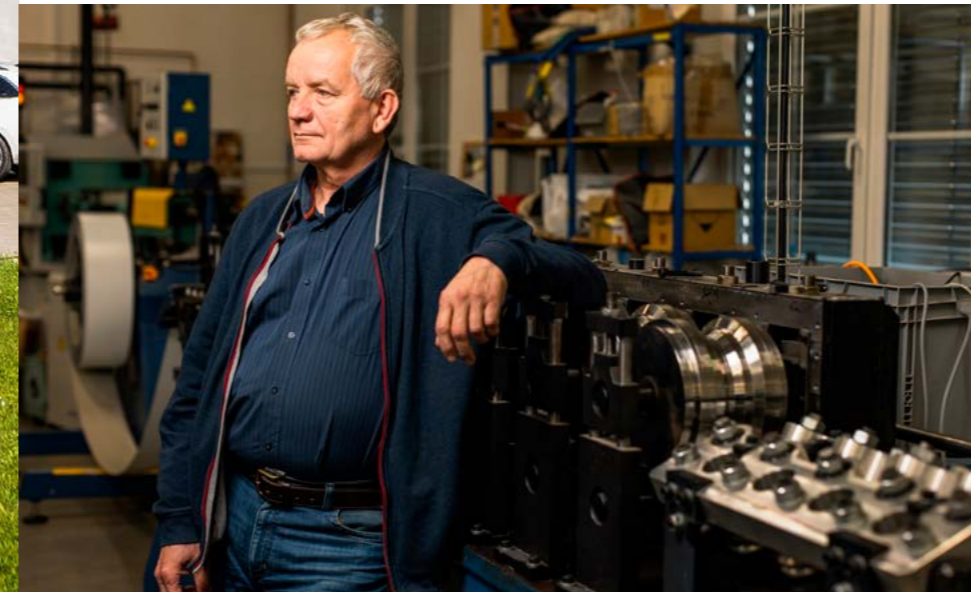

## ABOUT ZEBR COMPANY

# 30 years of experience

The company ZEBR is a regional company with a global presence. We are a reliable partner for our customers and have been delivering them with unique solutions for the production of shading technology for more than 30 years. We are constantly innovating our products and are able to adapt them to the needs of individual customers. Together with our customers, we grow and we advance the entire field of exterior shading.

We are a leader in the field of automating the production of exterior blinds. Our machines bring reliable automation of the entire production process while maintaining compact dimensions and high productivity.

Connection with the customer's existing production system or the possibility of monitoring statistical data from production is a matter of course. Our machines are made of quality materials and fitted with components from renowned European producers.

We also offer our customers proven technology for the production of aluminium interior blinds. These machines also offer configurability in accordance with the exact

needs of the customer, full automation of blinds production and high reliability and stability of operation. Today, the BETA machines are already a standard of reliability and quality.

In addition to the machinery, we are able to supply and also develop various components for shading technology. Our press shop has ZAMAK 5 die-casting technology, it offers cutting and bending of sheet metal parts, injection of plastic parts and rolling of profiles.

Our common goal is a satisfied customer and our driving force is the constant innovation of products.



## MACHINES

# Interior blinds

The machines of the company ZEBR s.r.o. are intended for processing varnished aluminium strips. They provide shaping, cutting of required holes, cutting to the required length, or threading slats to the ladder.

We offer various degrees of automation so that the technology always meets the customer's requirements.



## Mašiny na okenní žaluzie

- ▶ BASIC CUTTING MACHINE  
SA 25-08
- ▶ AUTOMATIC MACHINE  
BETA NC
- ▶ ROLLING LINE  
CLX1DUO
- ▶ MANUAL MACHINE  
RSU 25-09

## AUTOMATIC MACHINE

# SA 25-08

The basic SA 25-08 model for start-up companies or companies with low production volumes is intended for cutting aluminium slats in the production of interior horizontal window blinds. The machine is only used for forming 25 mm wide slats and cutting holes. Threading the slats into the ladders must be done manually; all required operations are entered manually.

The machine is characterised by a simple structure, operation, high variability, reliability and productivity.



Active unwinding

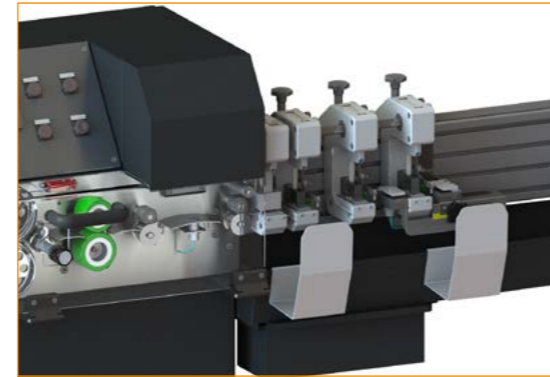

4 punching tools (fixing hole, texband hole: full shading design)

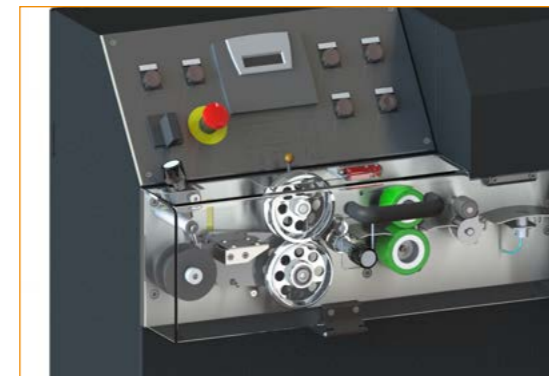

Forming section



Separate stand with a cube



Quick and easy feeding of slats into the machine



Possible turning on and off the fixing holes



Quick adjustment of blind dimensions



Punching and dividing of slats in one cycle



Easy change of tools using an Allen wrench



Continuously adjustable speed



Technical sheet for download

## AUTOMATIC MACHINE

# BETA NC

Modular machine for maximum production efficiency. The flexibility and degree of automation of the equipment depends on the customer's needs. The machine is equipped with automatic threading of the slats into the textile ladder.

Possible processing of slats with the widths of 10; 12.5; 15; 16; 25; 30; 35 and 50 mm.



Active unwinding

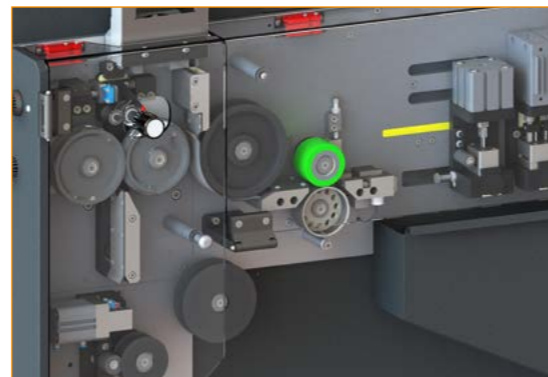

2 punching tools (fixing hole, texband hole – standard or fully shading design)









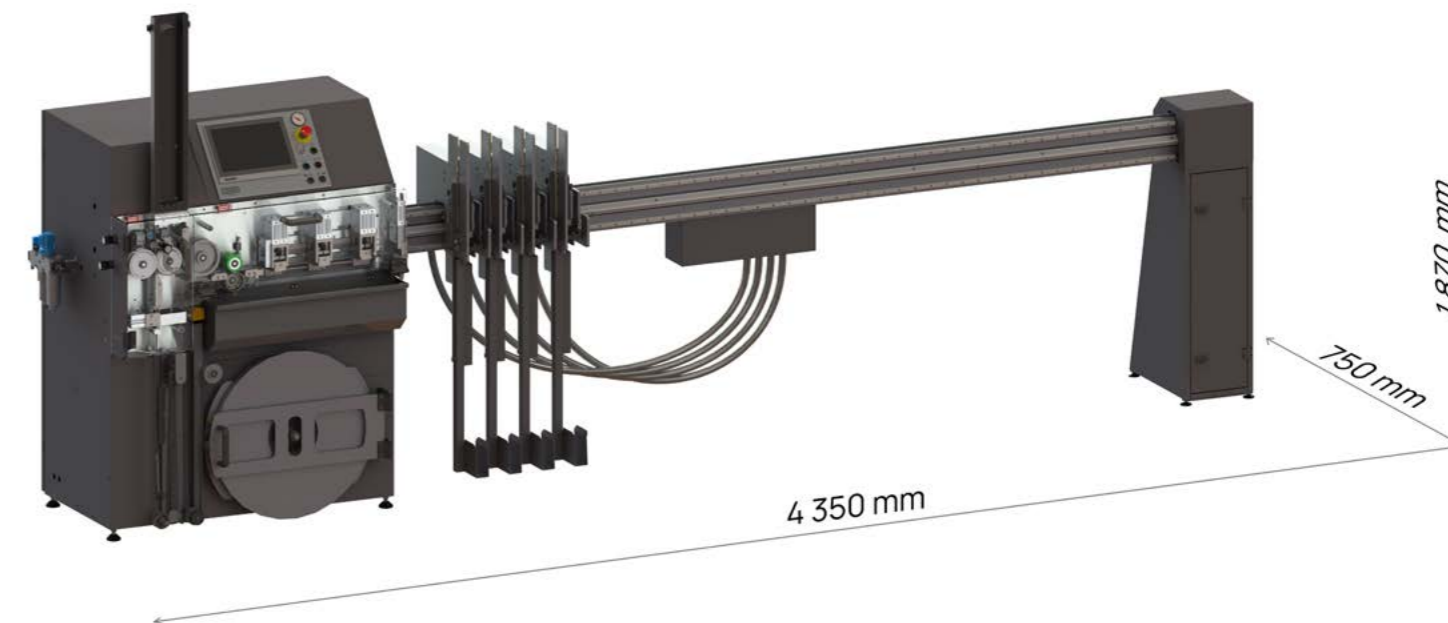

Control panel with a touch screen



Stand



-  High productivity
-  Waste disposal
-  Easy change of tools
-  Possible connection with ZEBR Cloud

-  Automatic loading of the slats
-  Threading into the ladder
-  Automatic cutting of the ladder
-  Automatically disassembling stands
-  Touch screen



Technical sheet  
for download

ROLLING LINE

# CLX1 DUO

Universal rolling line intended for the production of upper and lower profiles, including its punching, cutting with possible automatic insertion of plastic parts into the upper profiles directly on the machine.



Unwinding system

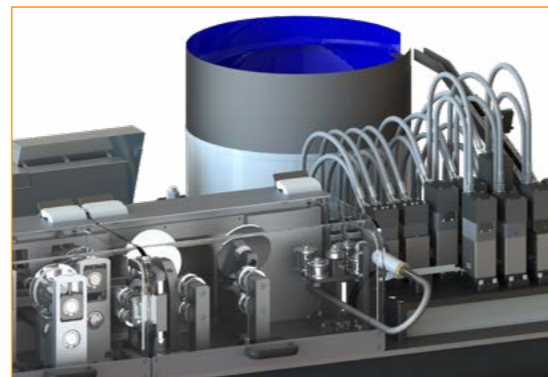

Tools



Control panel

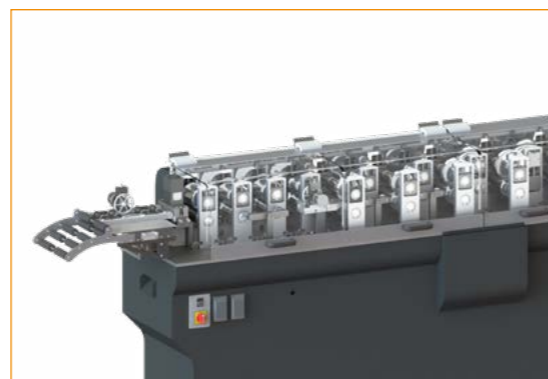

Rolling track

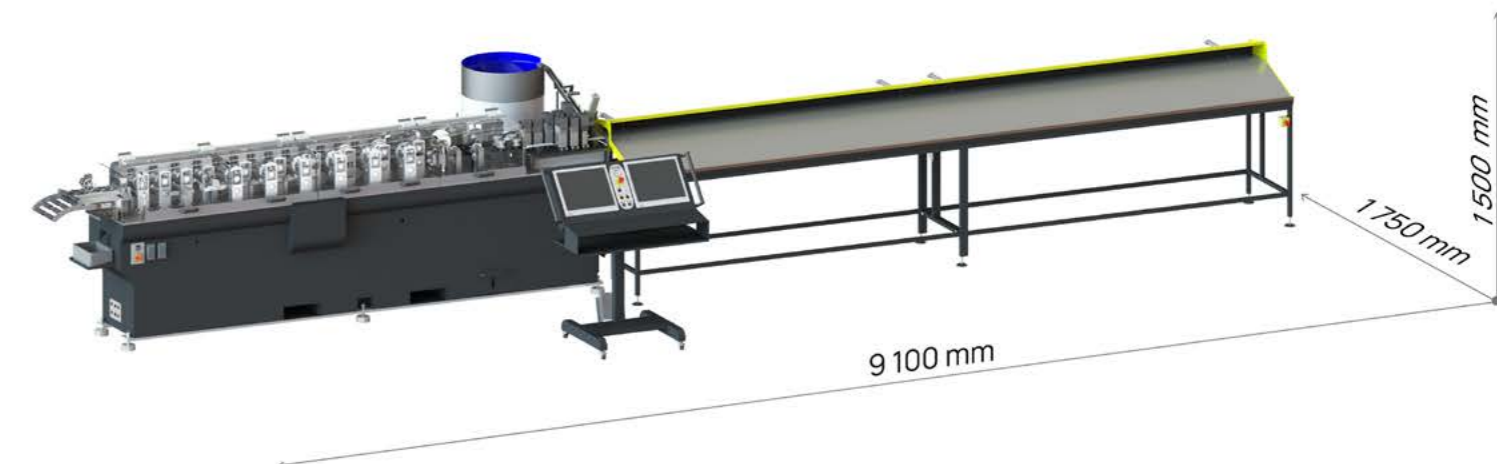

High productivity



Possible custom or metered production



Possible connection with the customer's ERP system



Parallel production of the upper and lower profiles



Marking of the upper profile using Laser-JET or INK-JET technology with the possible barcode printing



Stacking table



Inserting a plastic bearing into the upper profile



Cutting of profiles to the required size



Punching of all necessary holes in profiles



Technical sheet for download



## MANUAL TOOL

# RSU 25-09

Manual tool for processing profiles of horizontal interior blinds. The tool processes the upper and lower profiles simultaneously. The tool performs hole punching in the upper profile for the bearing, the cutting of the upper profile with possible punching of the fixing holes, the punching and cutting of the lower profile. The tools can be placed on a measuring bench with movable stops. The profiles must be moved manually.

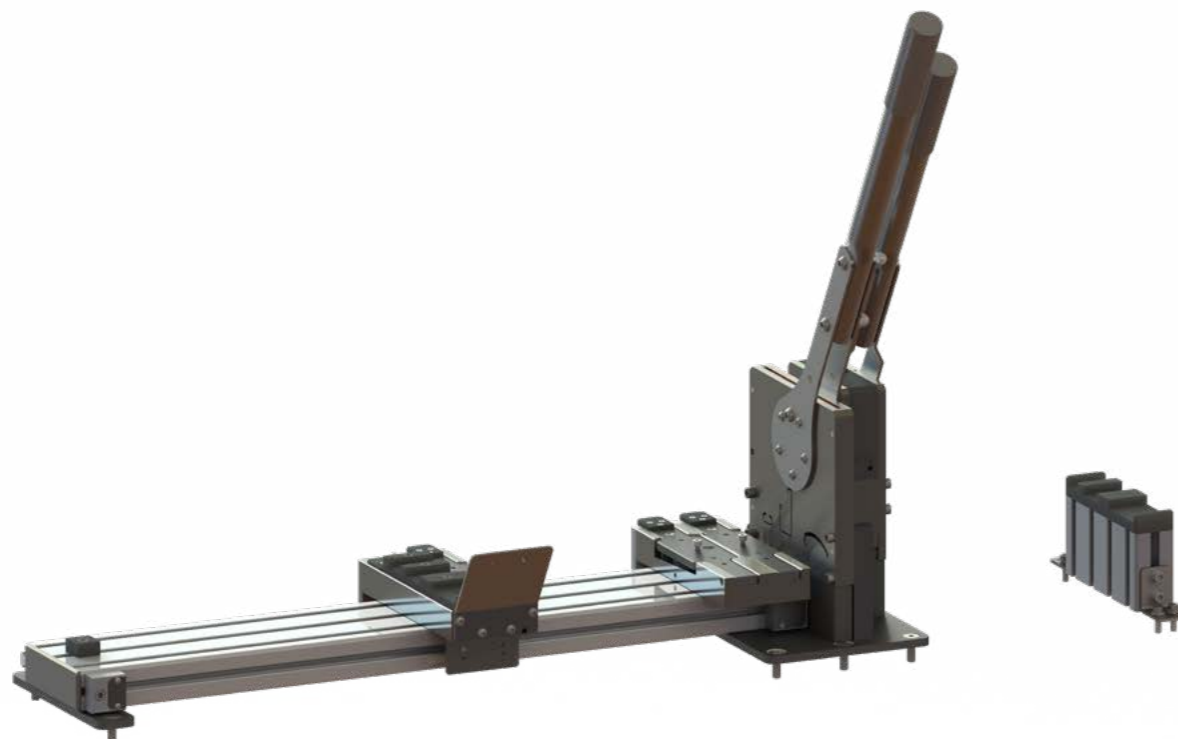

### Features:

- possible addition of another tool, e.g. cover, etc.
- simple stop system
- easy maintenance
- high tool lifetime



**Technical sheet  
for download**



MACHINES

## Exterior blinds

Rolling lines intended for the production of horizontal exterior blinds for the processing of all types of commonly used slats. The exterior blind machines enable full automation of the overall production process and at the same time they offer a unique method of solution for any customer.



## Offer of machines

ROLLING LINE  
VT 12NC START  
VT 12NC  
VT 12NC RDS  
TRIANGL14NC  
TRIANGL14NC RDS  
VT 12NC HP

AUTOMATIC MACHINE  
ZK COMPLETO  
HSP 50NC

## ROLLING LINE VT12NC START

A single-purpose rolling line for the production of one horizontal exterior blind - type Z90 or C80. The machine processes metal sheet measuring 113 x 0.42 mm for the Z90 profiles or 94 x 0.42 mm for the C80 profiles.

The VT 12 START model is designed as an affordable alternative for starting or small producers. Later upgrade of this machine is not possible.

The resulting product is a slat rolled into the required profile, with a given number of texband and fixing holes, with hooks, cut to the required length.



Equipment for **unwinding aluminium sheets** integrated in the machine

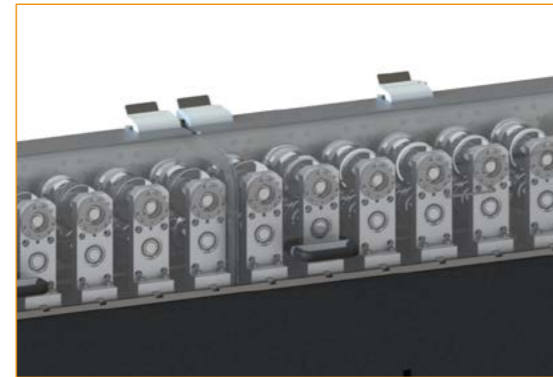

**Set of rolling wheels** including heat treatment (hardening)



**Control system with a 12" touch panel** with possible connection to the company network

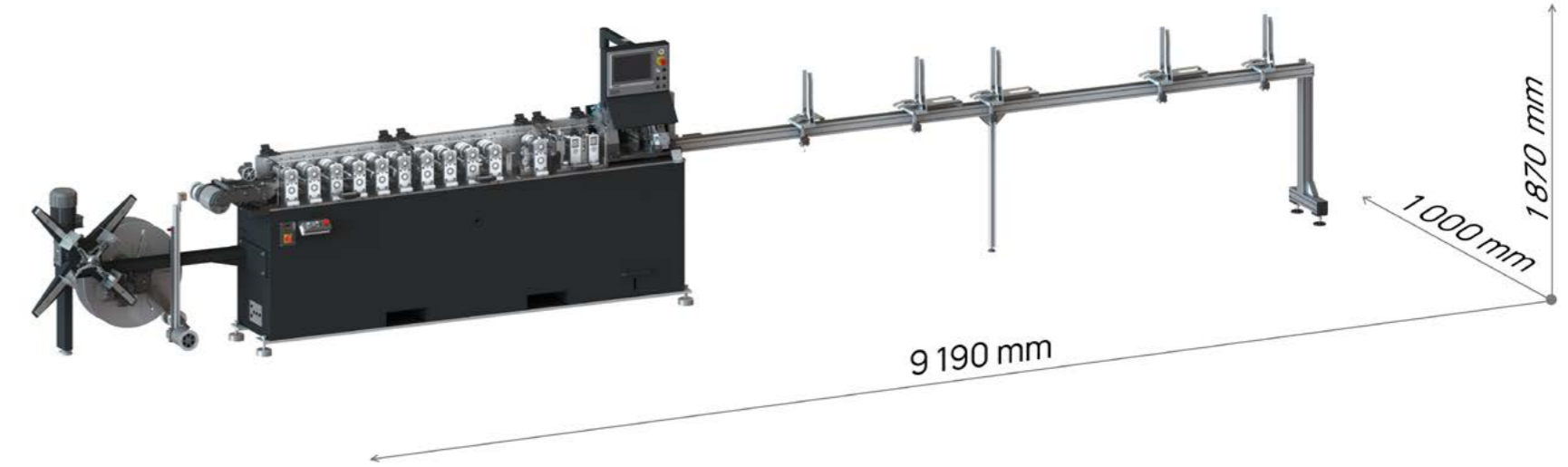

Simple entry of dimensions  
Possible connection of a barcode scanner



Easy adjustment of rolling speed



Possible connection of a barcode reader



Modem for remote diagnostics of machines



Punching of all holes



Automatic insertion of the hook into the slat rim



Automatic rolling of the rubber into the slat for the Z90 profile



Cutting tool



**Technical sheet for download**

ROLLING LINE

# VT12NC

A single-purpose rolling line for the production of one horizontal exterior blind, type C, S, Z or Flach (according to the customer's requirements). For this model, you can choose the semi-automatic option at the beginning and gradually move to the fully automated version.



Detail of packet C80



Detail of packet Z90

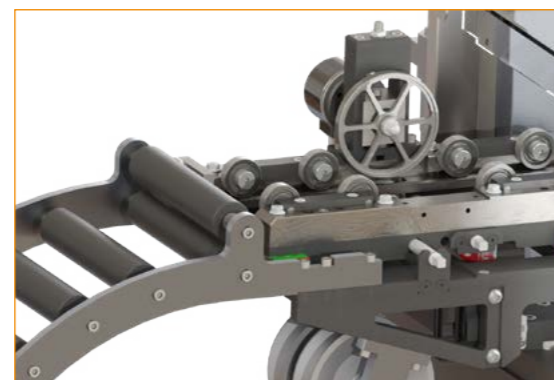

Guiding



Tool part



Savings thanks to automation



Production of complete packets



Possible connection with the customer's production system



Possible customer configuration



Punching of all holes



Application of guiding pins (welding / riveting)



Shooting a hook into the slat



Completion of the final product



High production productivity



Technical sheet for download

## ROLLING LINE

# VT12NC RDS

A single-purpose rolling line for the production of one horizontal exterior blind - C, S, Z or Flach (according to the customer's requirements). The RDS unit makes it possible to increase the daily production, depending on the optimized number of tools and their distribution, by 60-80% compared to the regular VT 12 NC machine. Productivity 100-120 packets per shift.

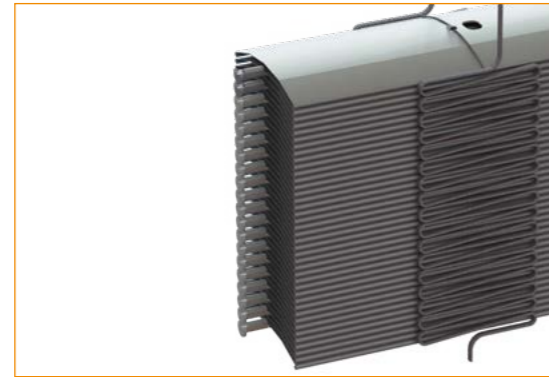

Detail of packet C80



Detail of packet Z90



Tool part



Rolling track



- €
Savings thanks to automation
- ⌘
Production of complete packets
- 4.0
Possible connection with the customer's production system
- 👤
Possible customer configuration
- ✂️
Punching of all holes
- 🔩
Application of guiding pins (welding / riveting)
- 🔪
Shooting a hook into the slat
- ⌘
Completion of the final product
- ⚙️
High production productivity



Technical sheet for download

ROLLING LINE

# TRIANGLE 14NC

A single-purpose rolling line for production of up to three slat types of horizontal exterior blinds - C, S, Z or Flach (according to the customer's requirements).

The tool change of rolling wheels is done by automatic rotation of the entire worktable, including the re-setting of all tool parts.

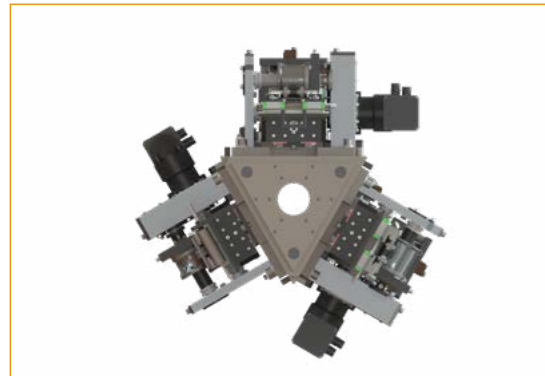
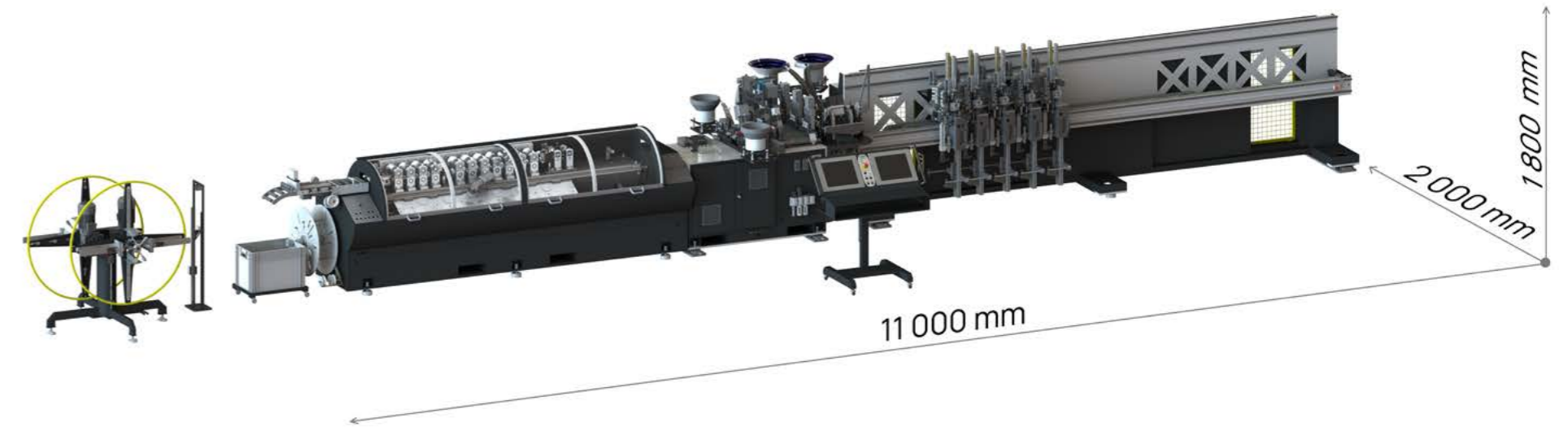

Detail of the rolling tracks

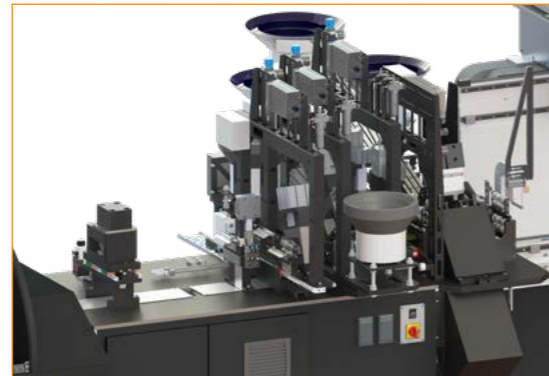

Detail of the tool part



Detail of the cutting tools

- €
Savings thanks to automation
✂
Punching of all holes
- 🏠
Production of complete packets
🔧
Application of guiding pins (welding / riveting)
- 4.0
Possible connection with the customer's production system
🔗
Shooting a hook into the slat
- 👤
Possible customer configuration
🏠
Completion of the final product
- 🔄
Flexible production, saving of space
🏠
Possible production of 3 different profiles



Technical sheet for download

ROLLING LINE

# TRIANGL 14NC RDS

A single-purpose rolling line for the production of up to three slat types of horizontal exterior blinds - C, S, Z or Flach (according to the customer's requirements). The RDS unit increases the daily production on this rolling line by 60 — 80 % compared to the regular TRIANGL 14 NC machine.

The tool change of rolling wheels is done by automatic rotation of the entire worktable, including the re-setting of all tool parts.

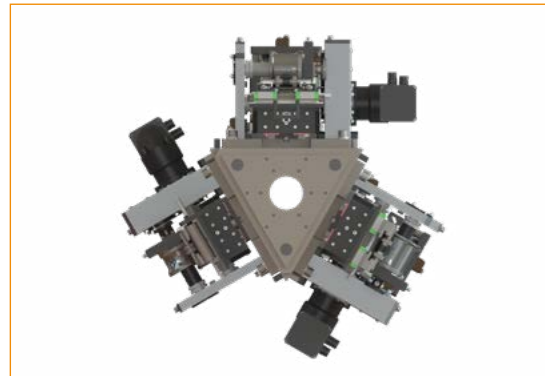
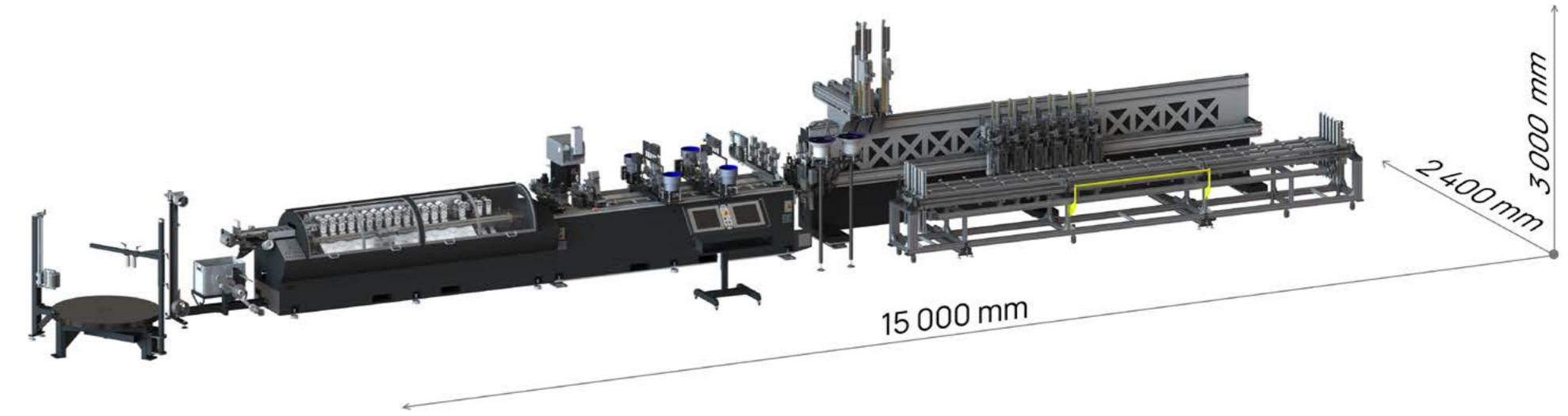



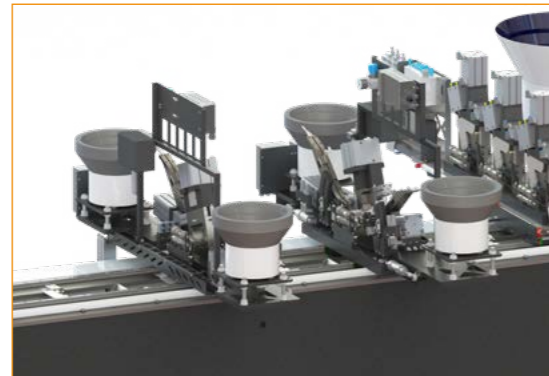







Detail of the rolling tracks



Detail of the tool part



Detail of the hook shooting

-  Savings thanks to automation
-  Production of complete packets
-  Possible connection with the customer's production system
-  Possible customer configuration
-  Flexible production, saving of space
-  High productivity
-  Punching of all holes
-  Application of guiding pins (welding / riveting)
-  Shooting a hook into the slat
-  Completion of the final product
-  Possible production of 3 different profiles



Technical sheet for download

## ROLLING LINE

# VT12NC<sup>HP</sup>

A single-purpose rolling line for the production and processing of horizontal exterior blinds upper profile. The VT 12NC HP model allows to process profiles in two ways: by directly entering the dimensions into the machine according to a job order or only the production of profiles in the length specified for further processing.

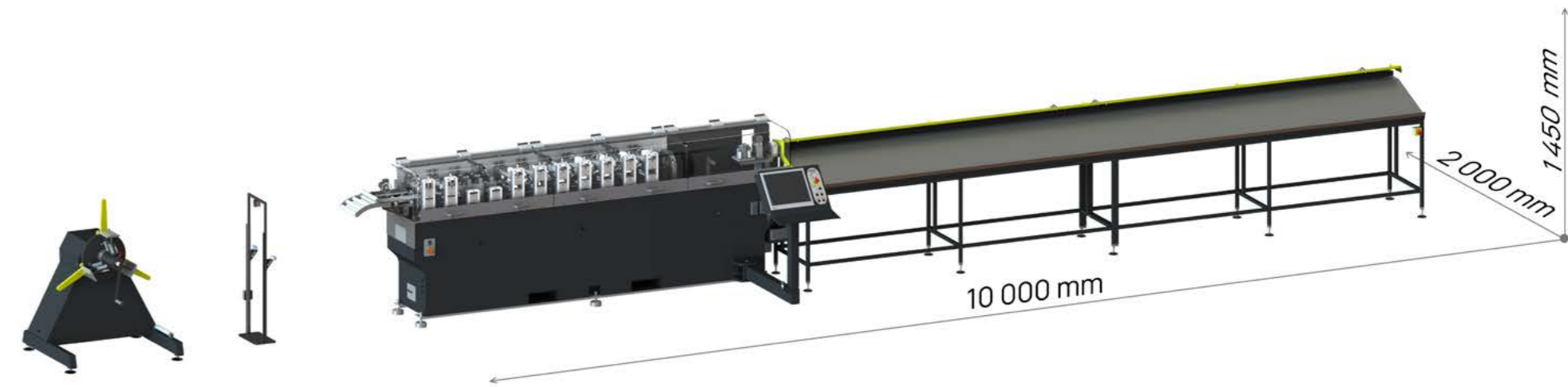

Detail of the profile with the inserted bearings

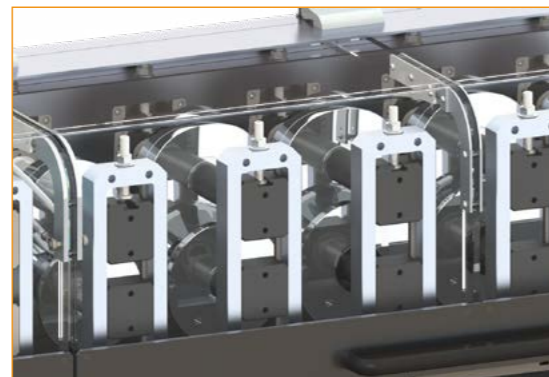

Detail of the rolling track



Detail of the tool



Waste-free production



Stable and productive machine



Possible marking of the labels using an inject laser



Punching of the required holes



Stacking table with automatic removal of the rolled profiles



Cutting to the required length



Possible automatic insertion of the bearings



Technical sheet for download



## OPTIONAL ACCESSORIES

Optional accessories for the VT12NC  
AND TRIANGL 14 NC machines.

### UNWINDING



### CUTTING

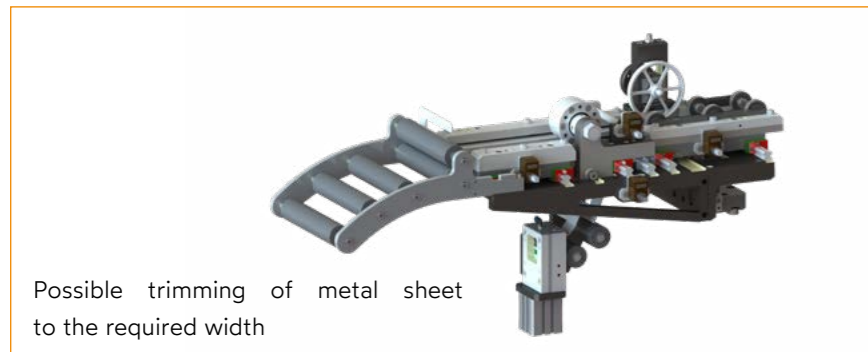

### SLAT MARKING



### SLAT COMPLETION

Threading device for type C and F slats,  
binding device for type S and Z slats



### CONVEYOR

Stacking conveyor for easier handling  
of the finished packets

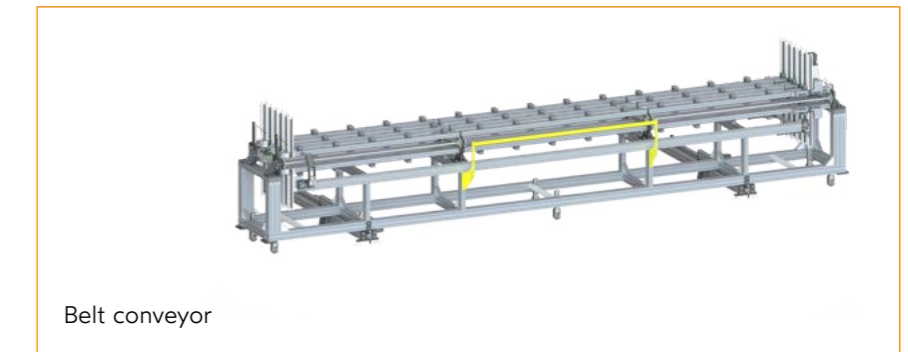
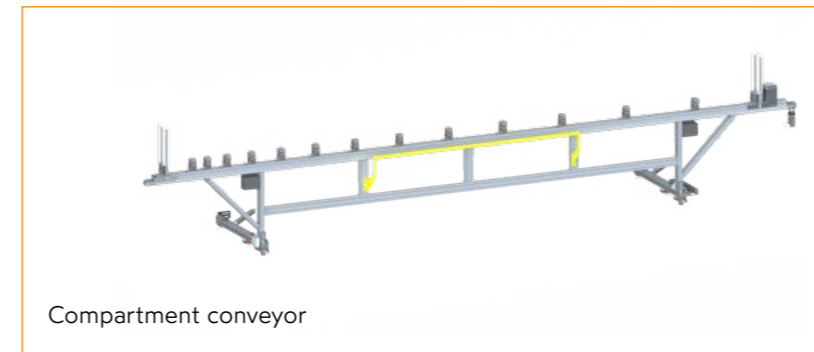

AUTOMATIC MACHINE

# ZK COMPLETO

This is an independent automatic machine processing rolled packets of exterior slats. ZK Completo model offers a solution for customers who want to expand existing facilities with the new technology.

This equipment has been designed as a modular system to meet specific customer requirements.

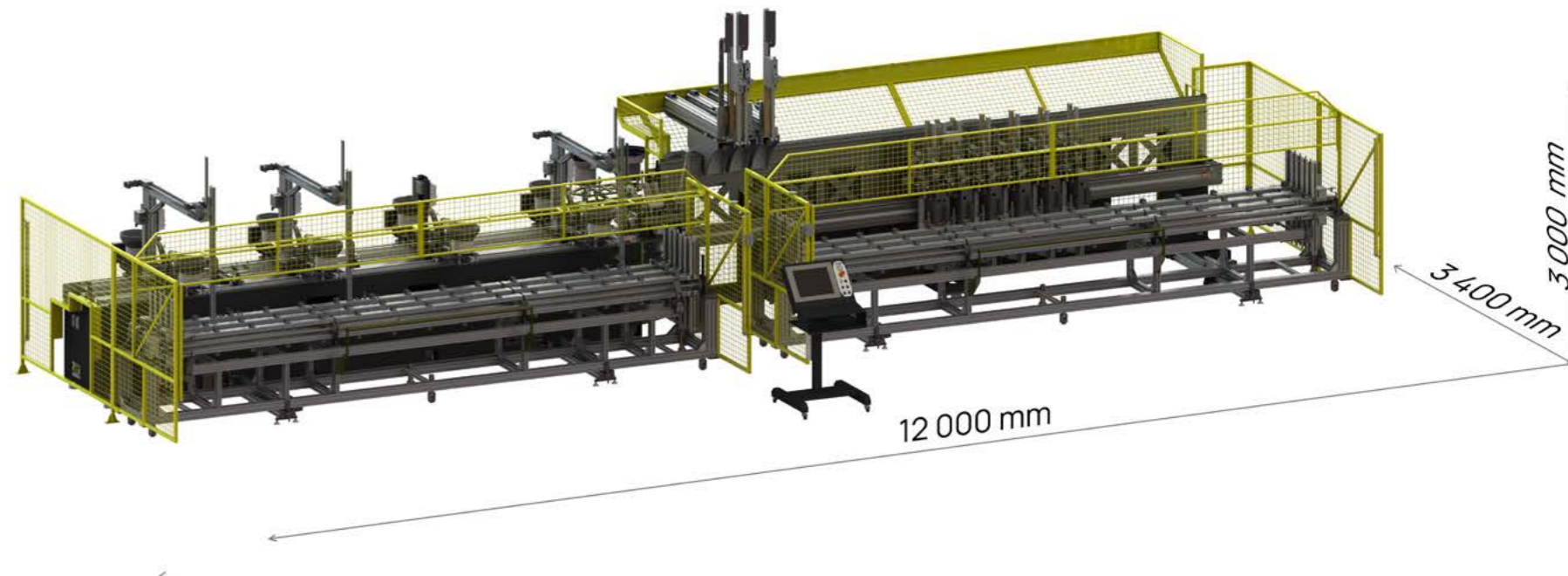

Detail of the Z90 packet

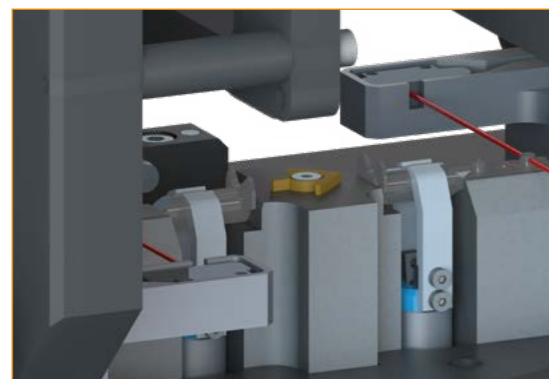

Detail of the riveting



Detail of the hook pressing



Savings thanks to automation



Production of complete packets



Possible connection with the customer's production system



Possible customer configuration



Possible addition of optional technologies



Automatic loading of the slats



Stacking table



Shooting hooks into the slat



Technical sheet for download

## AUTOMATIC MACHINE

# HSP 50NC

Separate automatic equipment that processes the already rolled or extruded upper profile for exterior horizontal blinds or the upper profile of the lower weight, or the cover profile for interior blinds.

The HSP 50 model processes the upper profile to the required length with different variability of holes and the number of produced pieces.

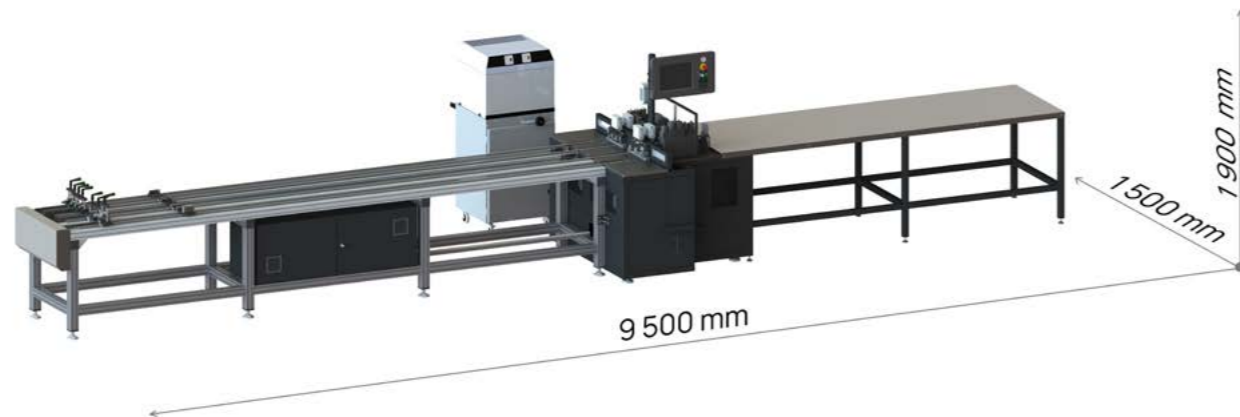

- Possible customer configuration
- Automatic shift of the loaded profile
- Suitable for companies with smaller production capacity
- Punching of all holes
- Possible simultaneous processing of the upper and lower profiles
- Modem for remote diagnostics of machines



**Technical sheet  
for download**



WE OFFER

# Accessories to machines

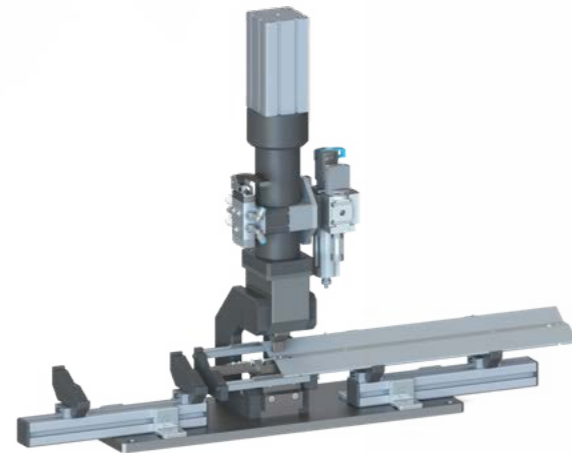

## HNK DEVICE FOR GUIDING PIN RIVETING

A simple device for pressing the metal guiding pins into the horizontal exterior blinds.

### Dimensions:

Length:	870 mm
Width:	200 mm
Height:	650 mm
Voltage:	400 V / 50 Hz
Pressure:	6 bar



## ASSEMBLY STAND

Intended for the inspection and installation of interior and exterior blinds. Electric motor drive with a transmission mechanism.

### Technical parameters:

Types of structure:	Single column
Dimensions:	4,000 x 4,000 x 520 mm
Work load:	80 kg
Weight:	105 kg
Power supply:	3NPE 220/127V 60Hz, TN-S
Input:	0,75 kW
Travel speed:	30 cm/s



## AUTOMATIC PLIERS FOR HOOK LOCKING

The automatically shooted hooks can be closed using manual pneumatic pliers or manual pliers when assembling the blind.



## SIMPLE MANUAL PLIERS FOR HOOK LOCKING

Manual pliers for closing the stainless steel hooks.



## RIVETING PLIERS

Manual pliers for riveting the metal guiding pins, especially suitable for smaller blind repairs at the installation site.

WE OFFER

# Services and technology

AVAILABLE TECHNOLOGIES:

- ◆ ROLLING
- ◆ PRESSING AND CUTTING
- ◆ INJECTION
- ◆ RAPID PROTOTYPING
- ◆ PRESSURE ZINC DIE CASTING



## TECHNOLOGY

# METAL FORMING

### ROLLING

Profile rolling according to the specified dimensions and parameters on our rolling lines.

 MATERIAL  
Steel sheet  
Aluminium sheet

### PRESSING OF SHEET METAL PARTS

Production of sheet metal parts used for interior blinds and insect screens. We offer several sizes of eccentric presses for forming.

 MATERIAL  
Steel sheet  
Aluminium sheet



## PLASTIC INJECTION

### MOULDINGS

- Production of technical mouldings from thermoplastics
- Calculation of the price of mouldings and moulds
- Development and cooperation in the manufacture of new mouldings
- Creation of pre-production prototypes – Rapid prototyping
- Structure of moulds, production of moulds, maintenance of operated moulds
- Patterning, design of materials, colours
- Pressing of plastic parts and components

 MATERIAL  
PA 6, ABS, PS,  
ASA, POM, PE, PC





## TECHNOLOGY PROTOTYPING

### DEVELOPMENT OF MOULDINGS

As part of prototyping, we offer component development using 3D printing technology. This technology offers quick testing of pre-series or small-series production with low costs for mould acquisition.

**MATERIAL**  
PA 6, ABS, PS,  
ASA, POM, PE, PC  
Possibility of colour  
versions, UV stabilizers  
and other additives



### PROTOTYPE CREATION PROCEDURE



1. Component measurement

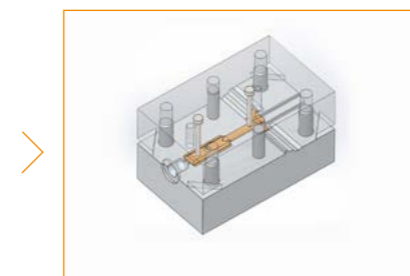

2. Design of the aluminium  
mould in our tool shop



3. Moulding production

## TECHNOLOGY PRESSURE ZINC DIE CASTING

### ZAMAK

Thanks to simple use, fast cycles (2 seconds/part) and low melting temperatures (400–500°C), zinc alloys (Zamak) are increasingly used in various industries – mechanical components in the furniture industry, automotive industry, etc.

We offer complex solutions, construction, manufacture of mouldings, including moulds.

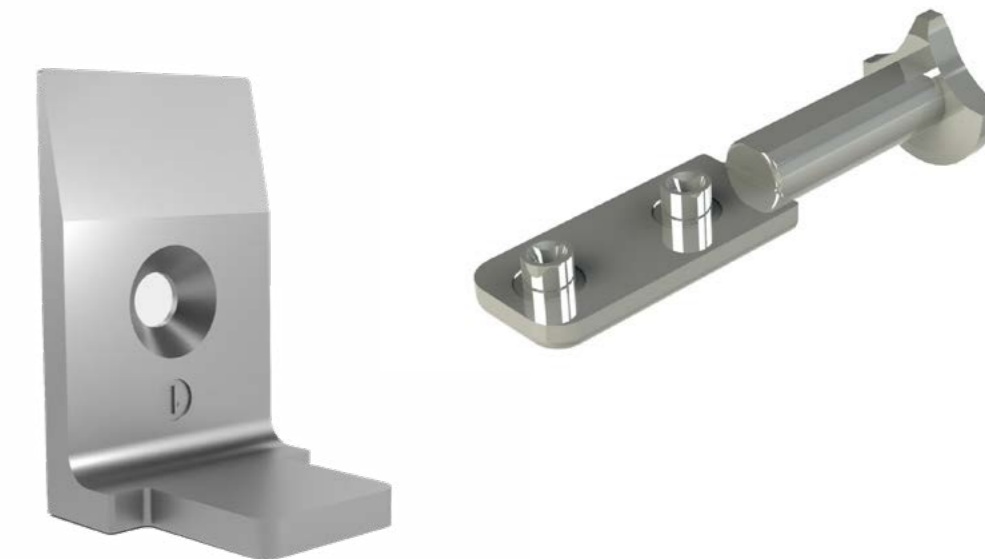

## PRESS SHOP Components

We offer a wide range of technologies for the development of new products or prototypes.

### TYPES OF COMPONENTS

- ◆ PROFILES FOR WINDOW SCREENS
- ◆ PROFILES FOR DOOR SCREENS
- ◆ ZEUS BLINDS SYSTEM
- ◆ PINS, HOOKS, SEALS

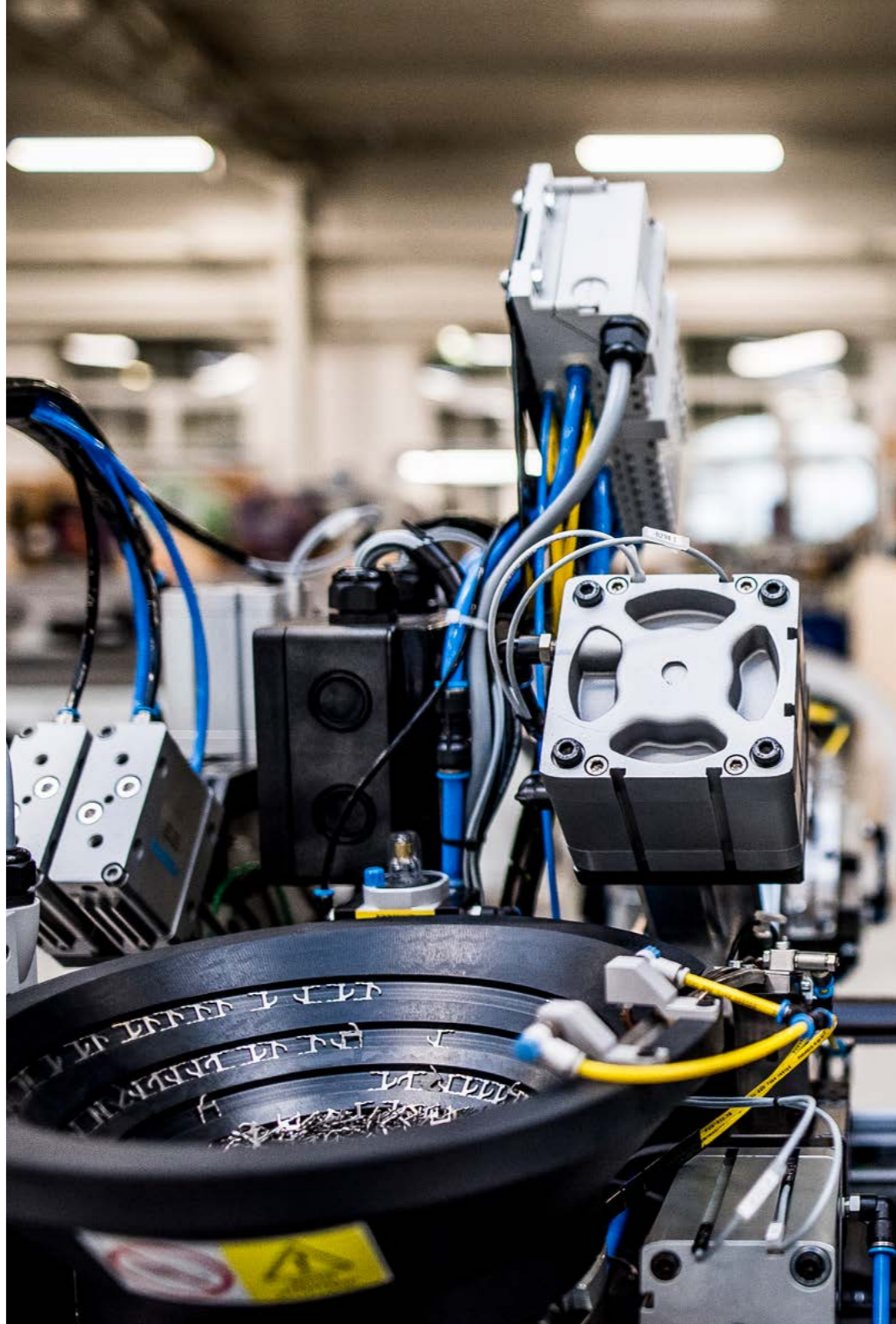

## WINDOW SCREENS PROFILES

**STANDARD**  
25 x 10 x 5,000 mm



**R50**  
33 x 11 x 5,000 mm

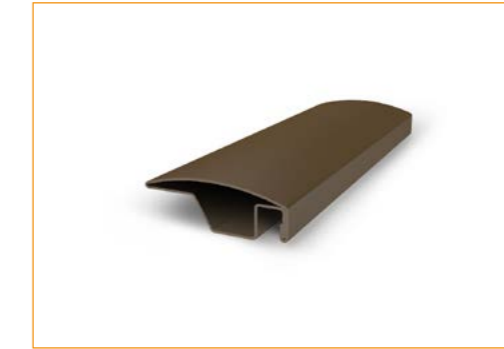

**LEM**  
31 x 12 x 5,000 mm



## DOOR SCREENS PROFILES

**DOOR**  
52 x 18 x 5,000 mm



**R18**  
50 x 18 x 5,000 mm



### COLOUR RANGE

We manufacture profiles and all visible connecting plastic components in seven standard colours. The customer can thus choose the colour versions according to his preferences. In the case of specific requirements, we also offer manufacture of other colours.

white

brown

wood

silver

walnut

golden oak

anthracit

## WE EXPORT FOR **the entire world**

If you are interested in the ZEBR products, do not hesitate to contact us. We will be happy to advise you and propose a suitable solution tailored to your needs.





### CONTACT DETAILS

ZEBR s.r.o.  
Milovice 178  
Czech Republic  
[www.zebr.cz](http://www.zebr.cz)

+420 777 753 551  
info@zebr.cz

### SOCIAL NETWORKS

 ZEBR\_CZ  
 ZEBR  
 ZEBR s.r.o.

WE START  
**Your  
Innovations**





